

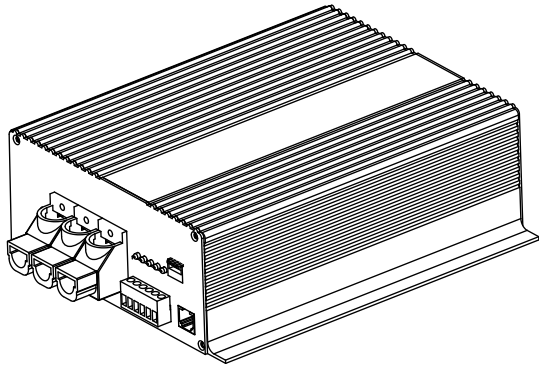

All-automatic battery charger
for motor homes and intervention
vehicles



Mounting Instructions and Operating Manual

■ B2B1260 ■ B2B1230

Features

This is a all-automatic DC-DC battery charger, you can use the battery (12V) to charge the battery (12V) (B2B), specially designed for RVs, exposed cars, campers, ships, etc.

B2B126030: 12V-12V/60A

BS123020: 12V-12V/30A

B2B Operation : mobile operation from dynamo and starter battery (Battery to Battery):

it refers to charging the main battery through dynamo and starter battery, .If it is not used in the Vehicle , you can also use one battery (12V) to charge another

1. The efficient charging converter (booster) allows full charging of the board battery during driving.
2. It increases/reduces the voltage to the level, which is required for precise charging of the board battery with the optimum characteristic line of charging.
3. The simultaneously supplied 12 V consumers are protected against overvoltage and voltage fluctuations.

Further Characteristics of the Unit

- The output voltage is stabilized, free of peaks, smoothed and filtered.
- Galvanic isolation between input and output:
- No overvoltage at the output and thus protection of the consumer if the ground line is lost.
- Clean, undisturbed mass ratios, even with long supply lines.
- Stable operating voltage on site in mobile operation, e.g. Containers, trailers, roll containers etc.
- Filtering and suppression of disturbances on the input to the output side.
- Fully automatic continuous operation: The DC-DC converter can constantly work with the battery
- Surveillance-free operation: multiple protection against overload, overheating, overvoltage, short circuit, Misconduct and deep discharge of the battery through electronic regulation to complete Switch off by built-in safety switch.

Security guidelines:

Intended use:

The DC-DC converter was built on the basis of the valid safety guidelines.

The use may only be:

1. On lead-acid, lead-gel or lead AGM or LiFePO4 batteries of the specified nominal voltage.
2. With the specified cable cross-sections for inputs and outputs.
3. With fuses of the specified strength near the battery to protect the wiring between the batteries and DC-DC converter connections.
5. In a well-ventilated room, protected against rain, moisture, dust and aggressive battery gases as well as in a non-condensing environment.

The device must never be used in places where there is a risk of gas or dust explosion consists!

Installation of the Unit

1. Install the charger near the board supply battery I (for short charging cables) at a clean, even and hard mounting surface, which is protected from moisture, humidity and aggressive battery gases. The unit can be installed in any position.
2. To be installed in a moisture-proof, water-proof place, corrosion-proof place
3. When the charging controller is working, the fan will bring out heat, so when installing, ensure that there is at least 10cm of space behind the charger controller
4. Choose the appropriate cable specifications, length and fuse specifications, reverse connection of the battery will cause serious damage to the equipment

Standard Connection

1. The "OK / TR" terminal function selects the "OK" function, and the "OK / TR" terminal is connected to a charging indicator

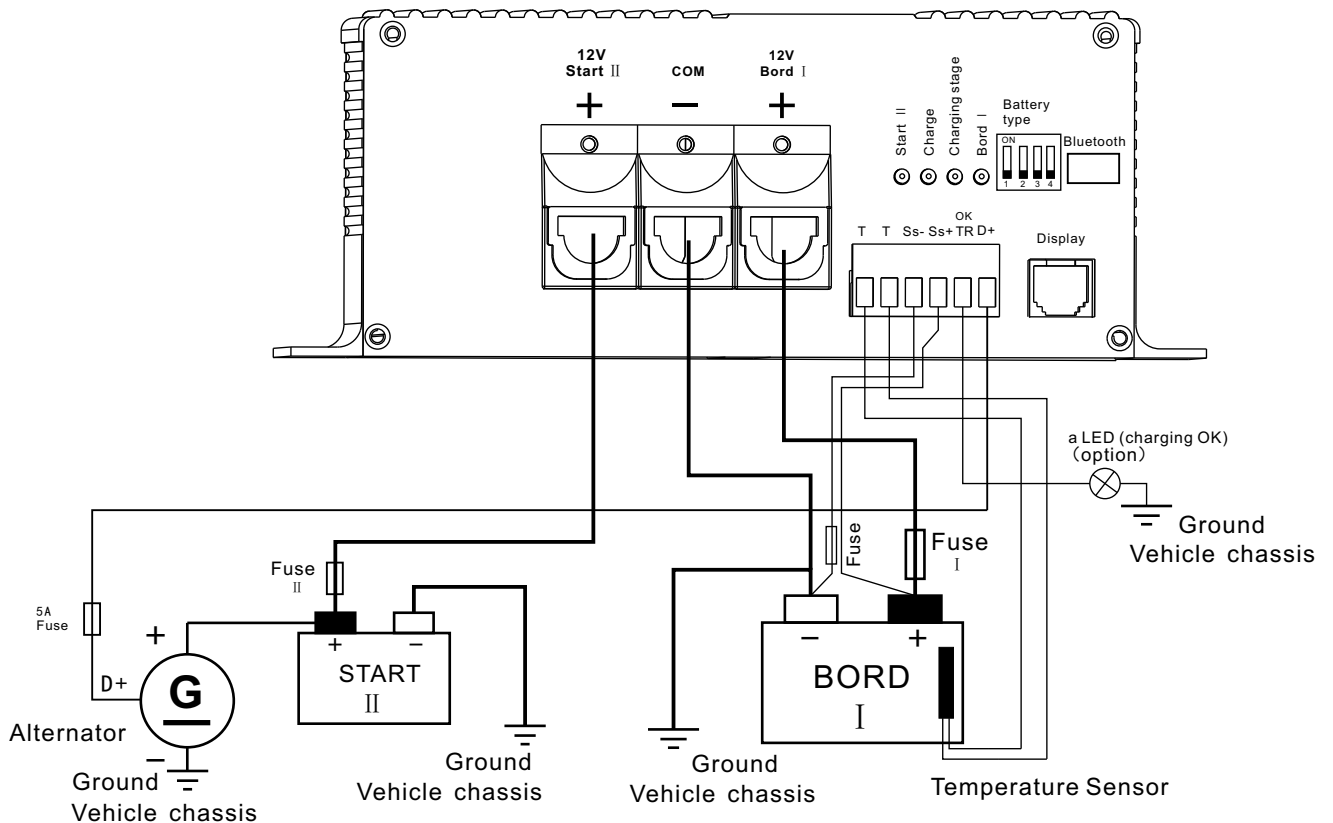

Connection Plan Special Case "TR"-ByPass Relay

in case of very high consumer current rates,

such as for air-conditioner operation during driving by means of powerful inverter

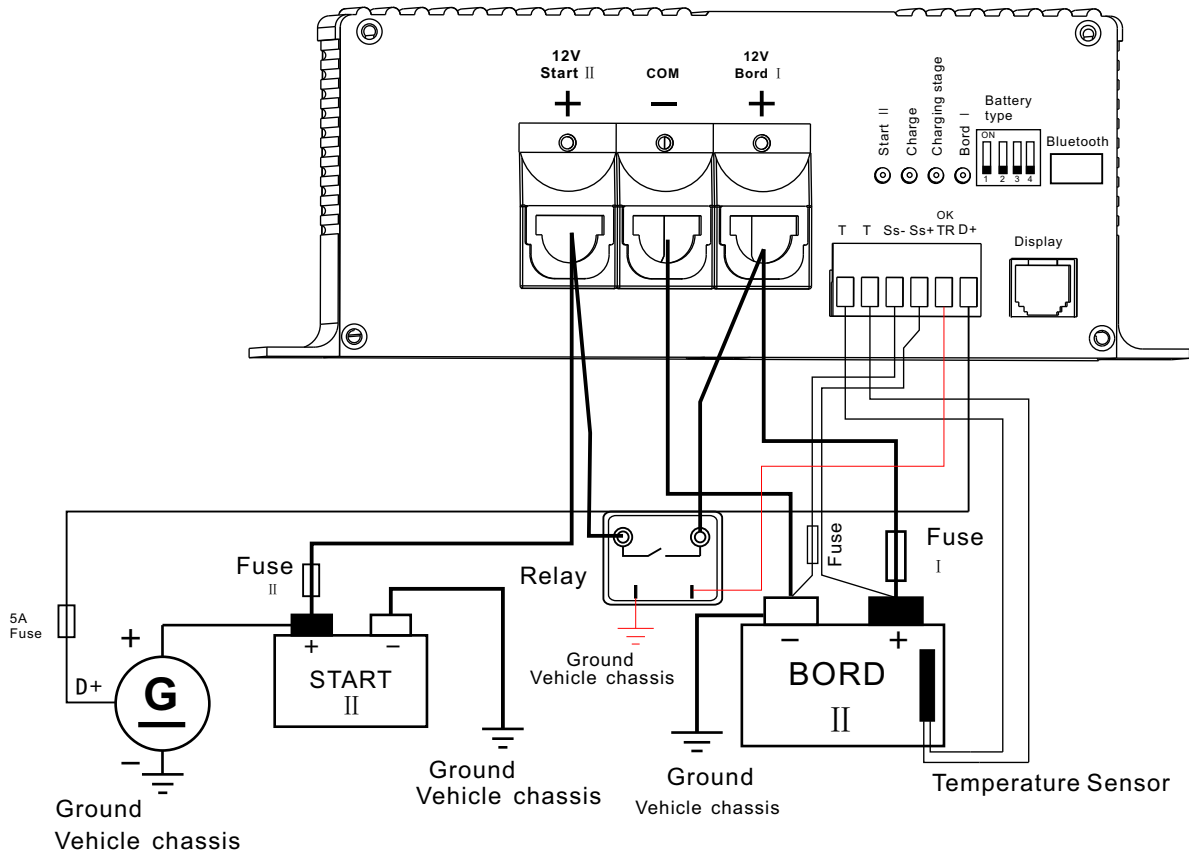

Recommended Cable Cross-Sections, Cable Lengths and +Fuse Capacities

B2B1260

cable cross section	cable length "+ Start II"	cable length with insulated construction "- Batt."	"Fuse II" cable protection	cable length "- Com." to "- Board I"	cable length "+ Board I"	"Fuse I" cable protection
4mm ²	-	-	-	-	-	-
6mm ²	-	-	-	-	-	-
10mm ²	-	-	-	0.5-2.0m	0.5-2.0m	80A
16mm ²	up to 7m	up to 7m	100A	1.5-3.0m	1.5-3.0m	80A
25mm ²	up to 10m	up to 10m	100A	2.5-5.0m	2.5-5.0m	80A

B2B1230

cable cross section	cable length "+ Start II"	cable length with insulated construction "- Batt."	"Fuse II" cable protection	cable length "- Com." to "- Board I"	cable length "+ Board I"	"Fuse I" cable protection
2.5mm ²	-	-	-	-	-	-
4mm ²	-	-	-	0.5-1.5m	0.5-1.5m	40A
6mm ²	up to 5m	up to 5m	50A	1.0-2.5m	1.0-2.5m	40A
10mm ²	up to 8m	up to 8m	50A	2.0-4.0m	2.0-4.0m	40A

Connection of the 6-pole Terminal Strip (Sensor Inputs, Terminals):

Plug-in Terminal Strip: In case of limited space, the strip can be withdrawn and inserted at any time for easy cable connection.

Cable Cross-Sections: 0.75 mm² or more

“**T T**”: Measuring input for the **temperature sensor** of the supply battery “**Board I**”

Connect the sensor (included in the standard delivery scope) to the terminals “**T T**” (any polarity). Further details concerning the functions of the sensor can be drawn from the paragraph “**Battery Temperature Sensor**” and from the characteristic lines of charging.

“**Ss-**” and “**Ss+**”: The cable sensor used to accurately measure the battery voltage helps the controller to judge the current battery voltage more accurately. Compensate the voltage loss on the charging cable. If this voltage sensor is not connected, or the connection is interrupted, it will switch to the normal measurement program

If multiple batteries are used in parallel, connect SS- to the negative pole of the first battery, and SS + to the positive pole of the second or last battery,

“**TR - OK**”: Charging indicator function or high current bypass relay TR function. For function selection, please refer to the “**Battery type switch table**”. If **not used**, the terminal is to be left free.

“**D+**”: Control input of the dynamo for the charging converter (B2B-Booster) operation ON / OFF:

Connect the terminal “**D+**” directly to the existing signal in the vehicle. The “**D+**” signal is preferably to be used for the "active dynamo".



If the D+ signal does not exist in the vehicle, the signal “Ignition ON” can be used for unit control. Attention:

When the motor is not running, the starter battery might be discharged!

Battery Temperature Sensor:

Connect the temperature sensor to the "TT" port ,and the other end to the main battery to measure the real-time temperature of the main battery ,ensure that the connection location of the temperature sensor is not disturbed by any heat source (including motor heat, exhaust, heater, etc.), When the temperature sensor is not connected or the temperature sensor is disconnected, the controller automatically switches to the default 25 °C

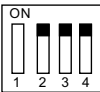
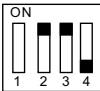
Set the battery type, “Bord I ”

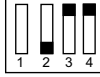
Switch Position	Battery type
	GEL
	Sealed
	Flooded
	LiFePO4
	Lithium-ion(NCM)

NOTE :

Four DIP switch, number 2,3 and 4 are used to select the battery type, number 1 is used to select the TR / OK function, as shown below

TR/OK function selection

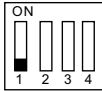
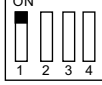
Switch Position	Function
	TR
	OK

NOTE :

Lithium battery must have BMS

Otherwise it is not allowed to be charged by the connected system

Battery charging parameters

Battery type	Equalized charge	Boost charge	Float charge	HVD	LVD	Constant voltage charging time
GEL	-	14.3V	13.8V	15.5V	11V	2h
Sealed	14.6V	14.4V	13.5V	15.5V	11V	2h
Flooded	14.8V	14.7V	13.5V	15.5V	11V	2h
LiFePO4	-	14.6V	13.8V	15.5V	11V	2h
Lithium-ion (NCM)	-	12.6V	12.5V	13.5V	9.3V	2h

Pilot Lamps:

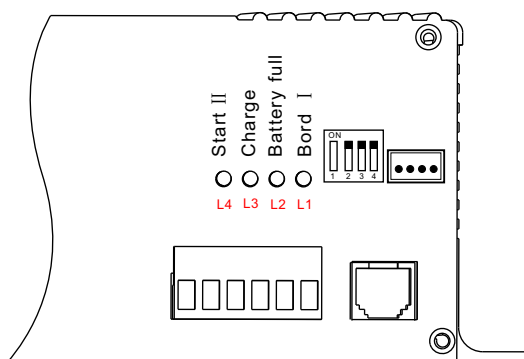

NO.	Name	Color	Stats
L1	Bord I	Red	Short flashing: Main battery voltage is normal (1 flash in 5 seconds) Fast flashing: Main battery over-voltage(1 flash per second) ON: Main battery Low-voltage
L2	Battery full	Green	OFF : no charging Short flashing: Boost charging (1time/5 seconds) Fast flashing: Constant voltage charging (1time/seconds) ON: Battery full
L3	Charge	Yellow	OFF : no charging Short flashing: The batter temperature is too high or the lithium battery is below -20 degrees (1time/2 second) Fast flashing: Controller overheating (1time/second) ON: charging (B2B or Solar charging)
L4	start II	Green	OFF : Solar charging or no D+ signal Flashing: start battery voltage<11V,(1time/5 second), (During B2B charging, when the voltage of the starting battery <10.8V, the charging will stop and the voltage will return to 12.5V Charging resumed, during this period, the indicator has been flicker) ON: start battery voltage normal(11V-16V)
Wrong battery selection			5 indicator lights flash at the same time, 1time/s

Operating

B2B Mode, generator and starter battery charge the main battery, (Battery to Battery)

1. When the ignition of the Vehicle is ON, the generator starts to work, the generator has a D + signal output to the controller, the starting battery will start to charge the main battery, when the stop driving, the generator stops working, the D + signal is interrupted, and the B2B charging stops .
2. When the start battery voltage $< 10.8V$, in order to prevent the start battery voltage from being too low and affecting the normal start of the vehicle, B2B charging stops. When the start battery voltage rises to $12.5V$, B2B charging starts automatically
3. When the B2B mode works, the solar charging stops automatically

B2B mode does not work, check the following questions

1. Whether D + signal is normal: D + signal voltage must be $> 8V$
2. Starter battery must be voltage $> 10.5V$, if the battery voltage is low, increase the generator speed to charge the starter battery

Charging process

1. **Boost charge**: Charge according to the maximum current until the battery voltage reaches the constant voltage charging voltage. Different battery boost charging voltages refer to the battery of charging parameters
2. Constant voltage charging : When the battery voltage rises to a boost charging voltage, the current begins to fall and enters constant voltage charging, and the constant voltage charging time is 2h.
■When the battery voltage is $> 12.6V$, the constant voltage charging is cancelled and the floating charging is directly charged
3. Floating charge : After the constant voltage charging is completed, the floating charging starts, the current decreases, and the battery voltage maintains the floating charging voltage. Reference charging parameters

Charging process

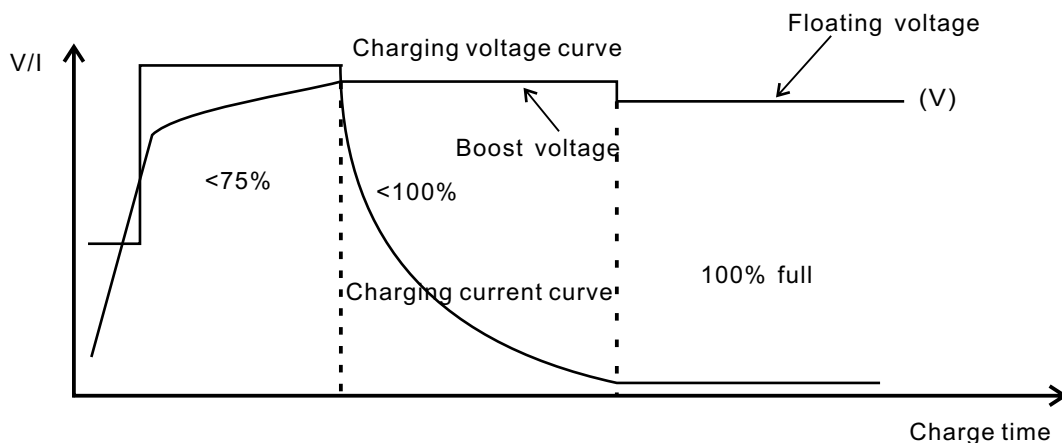

Protective function

Main battery over-voltage	Battery voltage>15.5V ,Charge off Battery voltage> boost charge voltage +0.2V,continuous10 seconds,charge off Buzzer alarm:Di-Di-Di,continuous 1 minute
Main battery Low-voltage protection	Battery voltage<11V Buzzer alarm : DiDi-DiDi-DiDi, continuous 1 minute
Starter battery low-voltage	11.6V-10.8V limit B2B charging current, <10.8V:B2B charge OFF
B2B charge, over-power protection	Max current 60A, Max power:780W
Reverse protection	Main battery: Blown fuse PV: no effect Start battery: Blown fuse
Overheating protection/ restore	temperature>85℃: Stop charging, Drop to 60 ℃: resume charging. temperature>80℃, B2B charging current drops to 50A, The temperature returned to 65℃, B2B returned to 60A charging Buzzer alarm: DiDi-Di-DiDi-Di, continuous 1 minute

Technical Data:

	B2B1260	B2B1230
Main battery "Bord I"		
Lead-Acid, Gel, AGM Batteries Nominal Voltage	12V	12V
LiFePO4 Nominal Voltage	12.8V	12.8V
lithium-ion (NCM) Nominal Voltage	11.1V	11.1V
Capacity (Battery Size), recommended:	90-560AH	45-280AH
Vehicle Starter Battery "Start II":		
Vehicle Starter Battery Nominal Voltage:	12V	12V
Min. Battery Capacity (Size), recommended:	100AH	60AH
12 V / 12 V B2B Charging operation		
Input Voltage Range "Start II", "D+" controlled:	10.5-16V	10.5-16V
Maximum charging power:	780W	390W
"Bord I" Max. charge current	60A	30A
Activation Control Input "D+"	8-16V	8-16V
Signal Output "OK/TR", Switch Position "TR", Cutoff Relay Bypass/max	12V/1A	12V/1A
Signal Output "OK/TR", Switch Position "OK"	12V/1A	12V/1A
Input "T T" for Battery Temperature Sensor "Board I":	YES	YES
"Ss-" "Ss+" Inputs Sensor Cables "-" and "+" for Battery "Board I":	YES	YES
stand-by current	24mA	24mA
Main battery overvoltage protection	15.5V	15.5V
weight	1.6kg	1.44kg
demension	190×215×70mm	190×194×70mm
Operating temperature	-20-50℃	-20-50℃
Optional accessories	Meter(MT-2) Bluetooth Dongle(BT10) Temperature sensor(RTS)	